

Connecting with Digital Tether™

Pinnacle Systems, Inc. • 280 N. Bernardo Avenue
Mountain View, CA 94043 • Phone: (650) 526-1600 • Fax (650) 526-1601
www.pinnaclesys.com • © June 2000 Pinnacle Systems, Inc.



Connecting with Digital Tether™

Carl Calabria, Laurin Herr & Patrick McLean

Overview

For years, designers of add-in boards for personal computer platforms have been plagued by one unavoidable challenge: how to make high quality connections from the board to the outside world.

The PCI specification provides for a very small rectangular opening through which all connections must be made to the card. This fence opening measures a mere 3.224 by 0.475 inches (~1.5 square inches).

This problem has been most pronounced for manufacturers with I/O intensive cards such as professional video authoring products where the number of input and output channels can be quite large. A modern video processing card typically supports several flavors of I/O (composite, s-video, component, SDI) and multiple channels of audio in an even greater number of flavors (unbalanced, balanced, AES/EBU, S/PDIF, TDIF). It is not hard to imagine why the problem gets to be such a challenge so quickly. The number of signal types can rapidly exceed 30 on higher end cards. In addition to the sheer I/O density, the matter of signal integrity has become increasingly significant as the video processing quality on these boards now exceeds that of many professional rack mount systems. And finally, the success of these products in professional applications have placed new demands on mechanical robustness, types of connectors employed, and long term reliability.

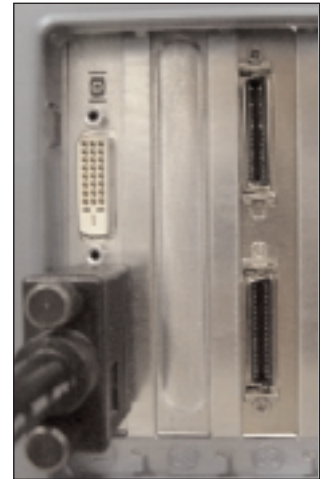

PCI Fence With Dual Digital Tether Ports of TARGA Ciné on Right.

Pinnacle Systems has engineered an innovative plug and play digital solution to address these problems by marrying SMPTE standard data formats with high bandwidth, low cost digital flat panel interface technology. The resulting invention, Pinnacle's Digital Tether Interface, provides superior performance on every metric and offers a level of product configurability unmatched in the industry.

Pinnacle's Digital Tether™ Interface offers multiple channels of bi-directional digital video, audio and control information on a compact, mechanically robust interface that can support 10-bit video standards up to 1080i with up to 16 channels of 24-bit embedded audio.

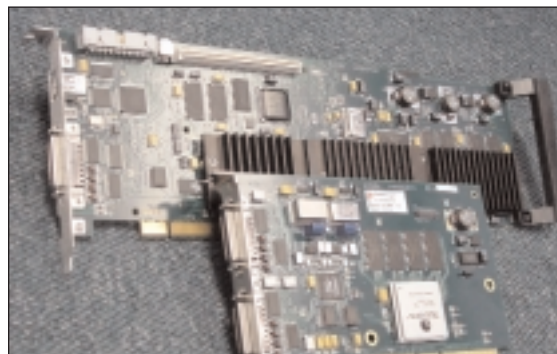

TARGA 3000 and TARGA Ciné With Digital Tether Ports on Left.

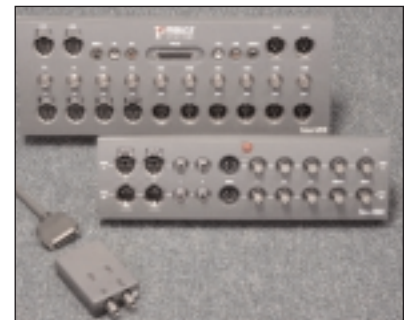

Digital Tether Break-Out boxes (BoB) for Audio and Video I/O.

Pinnacle's TARGA 3000 and TARGA Ciné cards are the first to support Digital Tether, and a full line of compatible analog and/or digital break-out boxes from industrial quality SD to broadcast quality HD are available or under development.

Connecting with Digital Tether™

The Basic Problem

Designers of PCI add-in cards for the video authoring market are faced with one fundamental problem. There is not enough space to fit all of the desired I/O connectors on the end of the card. The table below enumerates the number and types of connectors required for three typical market segments.

While it is possible to squeeze the requisite connectors for a consumer device on the PCI card, it is mechanically impossible to do so for higher end products.

The Solutions

To solve this fundamental dilemma, manufacturers have devised numerous strategies for providing the required connectors at a location other than on the end the PCI card. To date, each approach has involved different trade-offs.

The solutions to this problem fall into one of four categories based on the interface methodology employed.

- Passive Analog
- Active Analog
- Isochronous Digital
- Synchronous Digital

Passive Analog

Perhaps the most straight forward approach is the passive analog interface. This method employs a very high density connector on the PCI card which aggregates all of the various analog signals onto a cable assembly which is terminated with the individual native connectors for each signal type. All analog video processing is done on the PCI card.

This approach is simple and attractive from a cost perspective if you only consider the cost of the PCI card. The cable assembly, however, is another matter. Such a cable assembly may require as many as a dozen coaxial video cables and another dozen shielded twisted-pair cables for the audio. The cost of these cables is significant, as is the cost of the connectors at the end of each one. Manufacturing such a cable is very costly since mass termination techniques can not be used at either end. Hand assembly also introduces greater chance for error and inconsistency. Such so-called "medusa head" cables are well known in the industry for their lack of mechanical robustness and high rate of failure. The physical diameter of the cable and its corresponding lack of flexibility represent another undesirable attribute often cited by end users.

Using a high density connector to carry high bandwidth analog signals creates another set of problems. Because of the close physical proximity of individual pins in the connector and the lack of internal shielding it is very difficult to avoid crosstalk. Judicious use of interspersed ground pins and thoughtful pin assignment can help minimize the problem, but some amount of

Video Signal Type	Connector Type	Consumer (In/Out)	Industrial (In/Out)	Professional (In/Out)
Composite Video	BNC	1/1	1/1	1/1
S-Video (Y/C)	4-pin mini-DIN		1/1	1/1
Component Video	BNC x 3		1/1	1/1
SDI Digital Video	BNC			1/1
Unbalanced Audio	RCA (xN)	2/2	2/2	2/2
Balanced Audio	XLR (xN)		2/2	4+/4+
S/PDIF Digital Audio	RCA (xN/2)			2/2
AES/EBU Digital Audio	XLR (xN/2)			4+/4+
TDI/F Digital Audio	DB-25			1
	Total Connectors	6	18	31

AV Connector Requirements.

residual crosstalk can invariably be measured on systems using this approach.

Achieving respectable return loss is made very difficult due to the impedance discontinuities inherent in a cable assembly of this type. First, the characteristic impedance of the connections on a high density connector do not match the 75 ohm characteristic impedance of the cable, source and destination. Second, in order to solder a coaxial cable to one of the pins of the connector it is necessary to strip back some amount of the shielding and at the extreme ends of the connector to sharply bend the inner core. Both practices introduce more impedance discontinuities. As a wave propagates down a cable, it will reflect back off any such discontinuity and impair return loss.

Finally, it is very common in cable assemblies of this type to solder all of the cable shields together and to then connect to the ground pins of the connector. While this approach saves on labor, it introduces highly undesirable ground loops which increase the noise floor of the system. Unfortunately it is almost impossible to determine if a manufacturer has taken this short cut without dissecting the cable.

Active Analog

In order to reduce the size and expense of the analog interface cable, the active analog approach moves a portion of the analog signal processing to an external active break-out box (BoB). Transmissions between the PCI card and the BoB are limited to a single audio/video format to which, and from which, all other analog formats are converted or derived. A typical arrangement would employ component video and balanced audio for transmission. Analog format conversion and source selection is done in the BoB with analog to digital and digital to analog conversion done on the PCI card.

Reducing the number of cables directly reduces the size, cost, and complexity of the cable assembly. The previously cited issues of connector cross talk, impedance discontinuities affecting return loss, and the potential for ground loops remain. Although cost is reduced for the cable assembly, this approach requires an enclosure and power supply to house and power the active electronics as well a communication channel through which the BoB may be controlled.

Benefits do arise from the fact that a portion of the analog processing is moved outside of the host computer. The inside of a personal computer is a fairly hostile environment with respect to analog signal processing circuits. Great efforts are made to design enclosures that minimize electromagnetic leakage from the box, thereby localizing that energy to the inside of the computer. High speed digital processing circuits, motors (fans and disk drives), and switching power supplies generate substantial electric and magnetic fields which bounce around the inside of the PC. This electromagnetic interference can couple into sensitive analog signal processing circuits. Good circuit design, power supply decoupling, board layout, and shielding techniques help to minimize the amount of noise energy which is coupled into the audio and video signals. Even the best designs, however, are not totally immune. The best solution to this problem is to locate the analog circuits far away from EMI noise generators because field intensity falls off as the square of the distance. Digital signals, of course, are not susceptible to degradation unless the magnitude of the induced noise exceeds the logic threshold, which is very uncommon.

It stands to reason, therefore, that moving the analog circuits out of the PC can only improve matters. The passive analog approach, with all analog processing on board, is most compromised. The active analog approach represents a significant improvement, but is still not ideal.

When portions of the analog circuitry are moved off the PCI card another advantage is realized. The circuit designer is no longer constrained by the space limitations of a PCI card. The printed wiring board must be shared between the analog processing and digital processing components of the design. It is not uncommon for the digital circuits to occupy more than 75% of the board area. It is often necessary to make performance compromises when limited board space is a factor. For example, a seven pole filter gives way to a 3 pole filter so that it will fit in the allotted space. An external BoB offers relief from such space constraints.

Another important consideration for an external BoB is the convenience it affords the user. Rather than groping to make connections at the rear of a computer or chasing down the right connection on a "medusa head" cable, a BoB presents all the connection points at one convenient location. Some BoB designs even offer the option of rack mounting for full integration in a studio environment.

Isochronous Digital

The problems inherent with analog transmission are overcome with a digital interface. In this scenario all analog processing occurs externally in a BoB without any of the problems detailed above. The real beauty of an all-digital interface is that signal integrity is not compromised unless bits are dropped or corrupted. Over short distances it is quite straightforward to design digital interface with a zero bit error rate. By placing all analog processing in an external BoB it is possible to realize very high signal to noise ratios and to accommodate native connectors for all desired signal types.

High performance industry standard digital interfaces have emerged and offer impressive bandwidth. Already USB1.1 is available on most new computers, with a rate of 12Mbits/sec, but it is not really practical for the transmission of high quality audio and video. USB2 is on the horizon and is expected to eventually supplant USB with which it is backward compatible. USB2.0 is specified for a maximum bandwidth of 480 Mbps, but adoption remains to be seen.

IEEE 1394 is the ubiquitous digital interface on DV and Digital8 camcorders where it is used to carry compressed digital video and baseband audio data. IEEE 1394 is available on an increasing number of personal computers and is also available as an ISA or PCI card upgrade option. Other consumer and home A/V network applications are also emerging. A DV bit-stream requires less than 30Mbits/sec and fits easily into the available bandwidth of 100-400 Mbps. For this application, IEEE 1394 is a perfect fit and represents the best method for importing DV-compressed video data into a personal computer.

It would seem natural to extend the use of 1394 to include baseband video as the link between a video board or PC and an external BoB. Unfortunately, this is not practical.

Standard definition, 4:2:2 sampled NTSC video (10.5 Msamples/sec), using 8-bits per component requires 165.7 Mbits/sec. When 10-bit per component data is desired, the rate increases to 207 Mbits/sec assuming special packing and unpacking provisions are provided in hardware (packing four 10-bit words into five bytes). (When high definition signals are considered these rates jump to 995 Mbits/sec and 1.24 Gbits/sec for 8 and 10-bit 1080i systems, respectively.) Audio represents a fraction of the video bandwidth but is significant enough to warrant consideration. Eight channels of uncompressed, 24-bit audio sampled at 48KHz represents a bit rate of 9.2 Mbits/sec. So, the total bandwidth necessary for a standard definition baseband interface supporting simultaneous input and output with 8 channels of audio is 353.4 Mbits/sec for an 8-bit system and 432.4 Mbits/sec for a 10-bit system.

Although the current maximum data rate of 1394 is 400 Mbits/sec, this bandwidth is not all available to carry payload data and must be reduced by the overhead associated with the 1394 protocol. Two basic methods of data transfer are supported by 1394, asynchronous and isochronous. The isochronous mode, preferred for streaming media data types, features a "guaranteed" delivery rate by reserving a portion of the total payload with the

remainder available for asynchronous data. Typically, only 70 to 80% of the total data capacity is available for isochronous mode data transfer. It should also be noted that 1394 was designed to support a 63-node tree topology network in which the required bandwidth of each node must be subtracted from the total available.

Thus, even in a peer to peer configuration, 1394 does not currently have sufficient capacity to support simultaneous input and output of baseband video and audio for professional applications. In the future, this will change when the speed of 1394 increases as contemplated by the IEEE 1394b standard currently under development. Even with these changes, however, other issues remain. First, recovering a video clock from a 1394 interface is extremely difficult because data transmission is asynchronous with respect to the video sampling clock (even in the isochronous mode). Genlock applications require that an extremely stable video clock be recovered from the input stream, very difficult when 1394 is employed. Second, 1394 specifies connectors optimized for size and cost rather than mechanical robustness and positive retention, two highly desirable attributes in a professional environment.

Synchronous Digital

The professional video industry has long recognized the benefits of a synchronous digital interface for transmission of video and audio information throughout the studio. In the serial domain, this is embodied in the SMPTE 259M and SMPTE 292M standards, capable of 270 Mbits/sec and 1.485 Gbits/sec respectively, commonly referred to as SDI (Serial Digital Interface) and HD-SDI.

When Pinnacle Systems set out to define a digital interface standard between its next generation PCI cards and BoBs we decided to leverage these widely embraced SMPTE standards. From a strictly technical perspective 259M and 292M are ideal choices. A single BNC connector is required and it is possible to embed up to 16-channels of audio with the video data. Throw distances of 200m are possible over coax with mechanically robust connections. Numerous Pinnacle products already employ SDI interfaces and we offer SDI native BoBs to convert to and from the various analog formats.

Unfortunately, these serial digital interfaces are quite expensive. The chipsets used to support 259M and especially 292M are sold in extremely low quantities by PC standards. The result is high cost which makes SDI interfaces hard to justify simply to connect a BoB to a PCI card 2m away.

Pinnacle's solution was to invent a short throw, synchronous digital interface, called "Digital Tether" that combines SMPTE standard data formatting with low cost digital flat panel interface technology for a robust broadcast quality solution. We then extended this concept to embrace multiple channels and support for HD video and SDTI.

Digital Tether

Digital Tether is an all-digital, bi-directional interface between a PCI card and an external break-out box which carries video, audio and control information at rates up to 1.485 Mbits/sec in each direction. Low voltage differential signaling borrowed from digital flat panel interfacing is intrinsically immune to EMI radiation/susceptibility and requires minimal power for signal transmission. Because digital transmission is utilized, signal integrity is maintained with no loss in quality. Analog conversion is handled in the BoB where isolation from PC noise makes it possible to design with a very low noise floor.

Digital Tether can be operated in either a dual channel standard definition (SDTV) mode at 27MHz or a single channel high definition (HDTV) mode at either 74.25 or 74.25/1.001 MHz with the following capabilities.

	SDTV Mode (27 MHz)		HDTV Mode (74.25 MHz)	
	Input	Output	Input	Output
Video Channels	2	2	1	1
Audio Channels	32	32	16	16
VITC Channels	2	2	1	1
Bytes/VSync	16	16	16	16

Digital Tether capabilities.

Digital Tether supports NTSC and PAL timing in the SDTV mode and all HDTV standards through 1080i in the HDTV mode including 480p, 720p, and 1080p24. All data formats conform to their respective SMPTE standards. Video is carried over a 10-bit wide logical data path with embedded audio (16, 20 or 24 bit), VITC, and control information also per SMPTE standards. By embedding audio and control data, full use is made of the video blanking intervals which would otherwise carry redundant information. Embedding control information allows the BoB to be initialized and operated from the PC without the need for additional signals.

Digital Tether also provides +/-12V, +5V and +3.3V power from the host PC allowing low power BoBs to operate without an external power supply or numerous internal regulators. For BoBs requiring more power than can be sourced by the tether, an external power option is supported. Self resetting fuses are provided on all power supply lines to protect the host computer from excessive current consumption or accidental shorting of the cable. The host computer will be unaffected by a dead short on the Digital Tether cable and normal operation will resume after the fault condition is removed.

BoBs will identify themselves to the PCI card so that its capabilities may be properly determined and exposed to the user. A user wishing to upgrade their I/O capabilities need only swap one BoB for a higher end model. Conversely, a higher end Digital Tether compatible PCI card may be substituted for an entry level card and still make use of the original BoB. This level of flexibility provides a future-proof upgrade path while preserving the user's initial investment.

Any given BoB or PCI card is not required to support all potential capabilities of the Digital Tether interface. Rather, the interface has been designed in such a way that a given PCI card will query an attached BoB and determine what level of functionality can be supported by that combination of BoB and card. A PCI card, such as the TARGA 3000 for example, supports a single Digital Tether port in the dual channel SDTV mode. The TARGA Ciné supports two Digital Tether ports, each of which can support either dual channel SDTV or single channel HDTV modes.

Digital Tether employs a 36-pin mini-Centronics style connector with positive mechanical retention and an inexpensive shielded twisted pair cable that can be mass terminated for an extremely low cost solution. The cable itself is very small and quite flexible. Positive mechanical retention is achieved with two locking tabs which require simultaneous pressure on two release levers before the connection can be unmated.

Digital Tether Product Offerings

The Digital Tether technology is available from Pinnacle Systems in several break-out boxes that can be used with a variety of products. The chart below illustrates the BoB and its associated audio and video connections.

Conclusion

The Digital Tether interface represents a low cost, no compromise breakthrough to a problem which has plagued designers of PCI add in cards for years. This future-proof, broadcast quality solution supports a digitally transparent, multi-channel interface between a family of external BoBs and a family of add-in PCI cards with support for all video standards through HDTV.

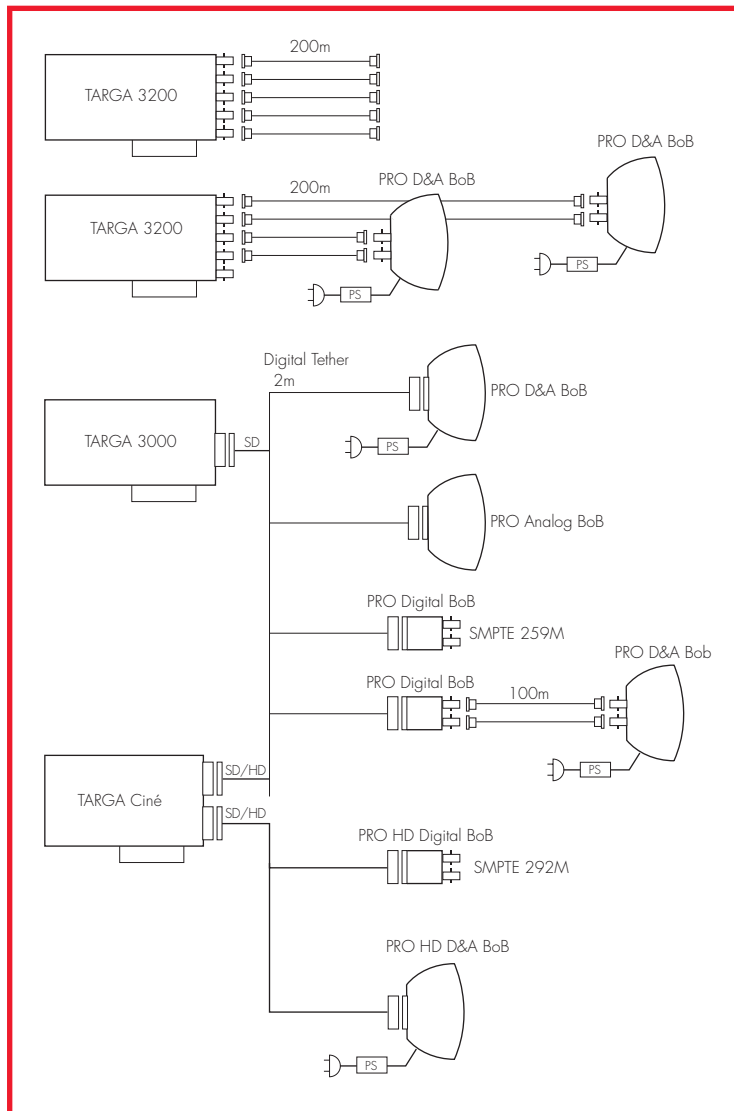

TARGA Connectivity Options.

Connection	Pro Analog	Pro Digital	Pro D&A	Pro HD
Component	1 Input, 1 Output	NONE	1 Input, 1 Output	
Composite	1 Input, 1 Output	NONE	1 Input, 1 Output	
S-Video	1 Input, 1 Output	NONE	1 Input, 1 Output	
SDI/SDTI	NONE	1 Input, 1 Output	1 Input, 1 Output	Input, 1 Output
Balanced Audio	1 Stereo pair Input & Output		2 Stereo Pair Input and 3 Stereo Pair Output	
Unbalanced Audio	1 Stereo Pair Input & Output		1 Stereo Pair Input & Output	
Embedded Audio		8-channel Input & Output	8-channel Input & Output	8-channel Input & Output
AES/EBU			4 Channel Input & Output	
S/P DIF			2 Channel Input & Output	

TARGA Digital Tether BoBs.